

filter management

DASTECS S.R.L.

Representantes / Distribuidores Exclusivos

Buenos Aires, Argentina

Tel.: (54-11) 5352-2500

E-mail: info@dastecsrl.com.ar

Web: www.dastecsrl.com.ar

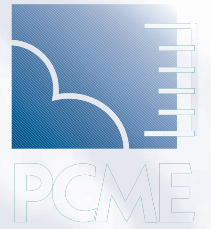

Emission Monitoring in the Carbon Black Industry

particulate emission monitoring

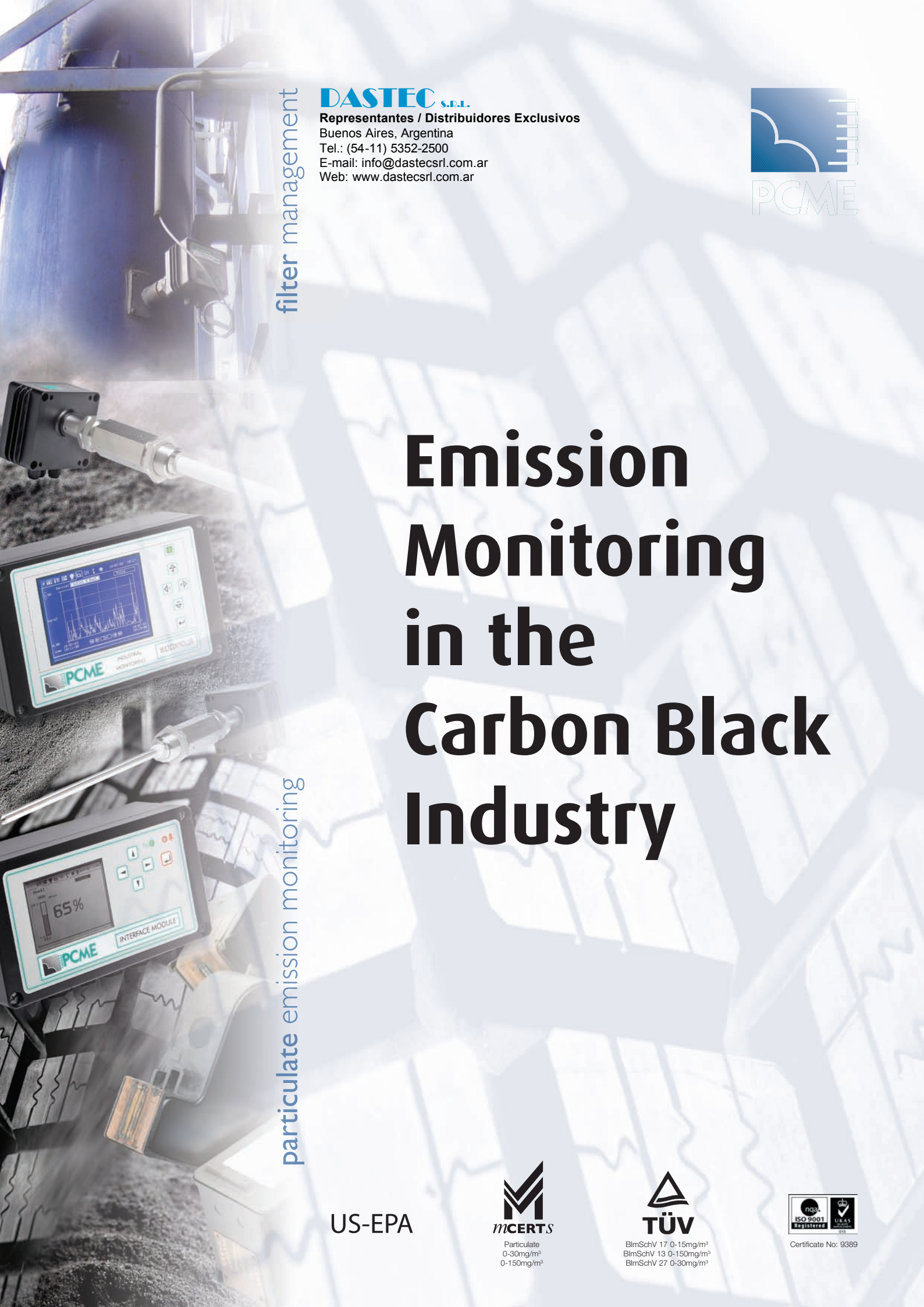

US-EPA



Particulate
0-30mg/m³
0-150mg/m³



BlmSchV 17 0-15mg/m³
BlmSchV 13 0-150mg/m³
BlmSchV 27 0-80mg/m³



Certificate No: 9389

PCME's solutions for carbon

PCME'S involvement with carbon black manufacturers over the last 15 years has led to the development of a unique range of unparalleled range of instrumentation to work in the difficult monitoring conditions associated with carbon black. These instruments reduce filter maintenance costs and production downtime.



Carbon Black Filter Plant with Electrodynamic Sensors

Monitoring Solutions

To overcome the problems normally associated with monitoring Carbon Black PCME's systems utilise a unique Electrodynamic monitoring technique incorporating a patented non contact charge transfer technique to monitor the extremely low dust levels normally associated with modern high efficiency fabric filters used for handling Carbon Black (typically 1 mg/m^3 or less). This measurement technology is featured in a wide range of accredited systems (MACT, TUV, MCERTS) to provide both indicative and calibrateable devices.



Electrodynamic Sensor with air purge

Unlike traditional Tribo-electric and Opacity systems whose reliability and functionality are effected by the coating effects of carbon black de-sensitising their sensing elements and its highly conductive properties short-circuiting Tribo-electric sensors, Electrodynamic systems are unaffected by the build-up of dust on the probe rod and will function with the sensor rod completely coated by dust. An air purge unit can be provided to prevent carbon particles from bridging the sensors insulated collar.



Sensor performance is unaffected by product build-up on sensing rod

Carbon Black & Paints & Toners & Printing

The formulation of compounds used in many manufacturing processes including the production of tyres, toners, printing inks, paints and rubber products utilise Carbon Black, one of the most highly visible and contaminating powders used in manufacturing industry today. Because of the potential for high levels of contamination if a filter fails many manufacturers of these products, together with the manufactures of Carbon Black itself, have successfully installed Electrodynamic environmental particulate monitors post filter to enable them not only to comply with legislative monitoring requirements but also to identify the failure of filter elements before serious levels of emissions occur. By utilizing the monitor as a maintenance tool in conjunction with PCME's Predict software package, many users have been able to make substantial savings in lost product, lower maintenance times, reduced filter spares inventories and by being able to accurately schedule maintenance, reduce the amount of lost production caused by traditional reactive maintenance programmes.

Carbon Black

CARBON BLACK INDUSTRY Oil Furnace Process

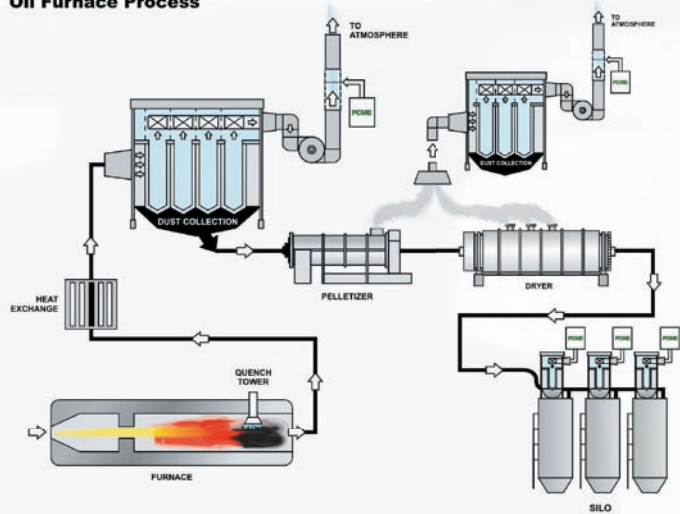

Carbon Black plant showing the typical locations of PCME systems

black users & manufacturers

range of particulate monitoring systems. Working in conjunction with some of the industry's key players, PCME provides instruments not only protect our environment by aiding legislative compliance but also decrease operator costs by helping to

Inks & Rubber & Tyres

A typical manufacturing process where Carbon Black is extensively used is in the production of tyres. Tyre plants commonly utilise a large number of fabric filters which may be in remote locations. To monitor these filters, PCME provide a wide range of Electrodynamic instruments ranging from single channel units to multi-channel (up to 32 sensors) systems. These sensors use modbus technology to network to a single control unit. The control unit logs historical data for environmental reporting and process control, displays emission values and allows easy configuration of the system.

The controller may be connected directly to a LAN to allow remote interrogation of the monitor by a number of different users, environmental, process, maintenance, etc. Both historical and real time data together with alarm status may be displayed simultaneously on different PCs and the Predict software package used to remotely diagnose filter maintenance issues.

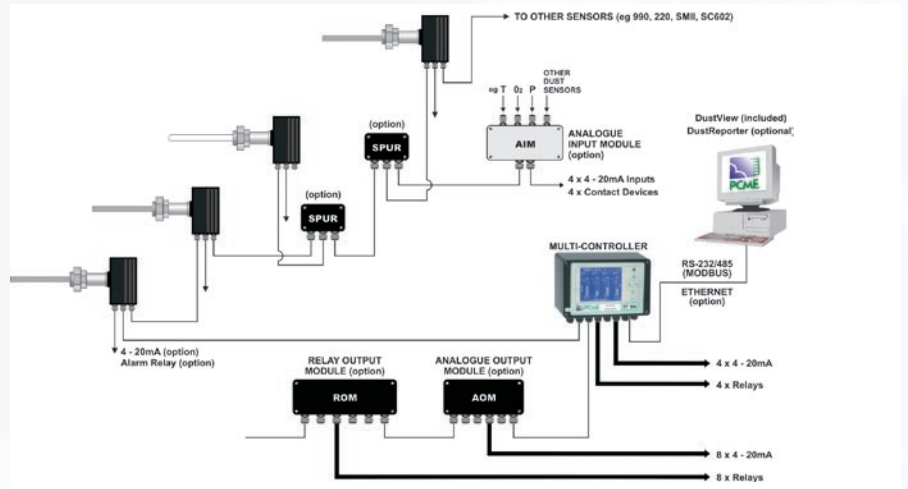

Typical networked system



LEV (above) & Talc plant (below) monitored utilizing a networked Electrodynamic system



Tyres//

TYRE INDUSTRY RUBBER

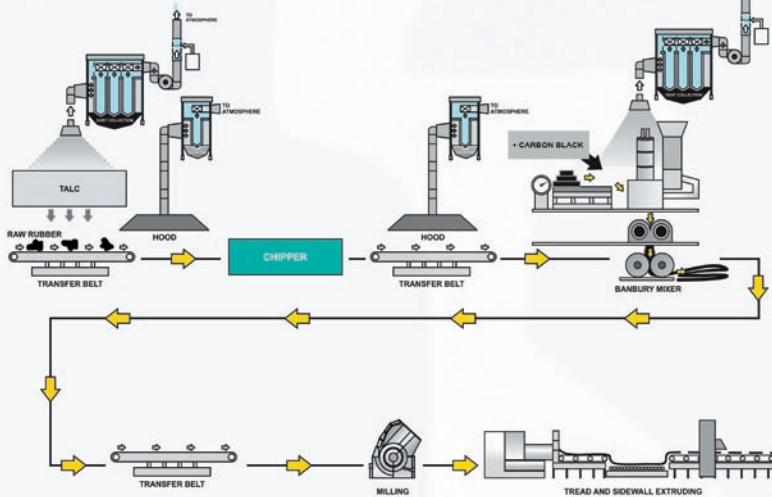

Tyre plant showing the typical locations of PCME systems



Advanced probe contamination check

To provide the utmost confidence in the integrity of the measurement, our advanced monitoring systems incorporate not only patented zero and span checks but also a unique patented secondary contamination ring which monitors any leakage currents or signals across the insulator thereby proving the measurement integrity of the sensor



Repeated process events displayed via DustReporter 2 software package

Cost and Environmental Nuisance Reduction using Filter Failure Prediction

The ability to predict when a filter is likely to fail and to be able to identify which row or chamber is at fault has provided users with a proven method to not only reduce the environmental impact and clean-up costs associated with large-scale carbon black emissions but also to make significant savings in spares, maintenance times and lost production. To achieve this, a monitor must be able to accurately track the very dynamic dust emissions created during a bag filter cleaning cycle.

As the filter is reverse jet cleaned, any defects in the filter membranes are exposed resulting in relatively high dust peaks. By monitoring these peaks in real-time using the Predict software package, it is possible to identify potential problems in the filter before they result in breaches of environmental limits. Predict provides the possibility to observe filter problems remotely and check maintenance work to ensure correct performance of the filter. The use of Predict has proven the ability of a monitor not only to be used for environmental compliance but also to be used as a significant aid to plant maintenance and also enables users to greatly reduce the instances of catastrophic filter failure.

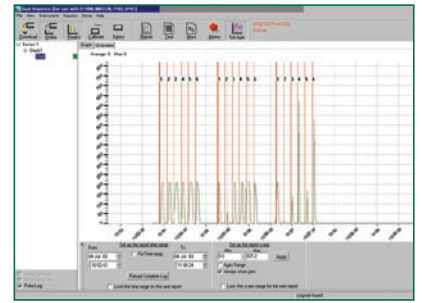

Real time identification of bag row deterioration

Electrodynamic Particulate Emission Monitoring

Principle of Operation

Proprietary technique based on a charge induction principle derived from particle interaction with probe inserted into a stack or duct. The instrument output is an analysis of this frequency response and in appropriate applications is a function of the concentration of particulate.

Applicability

- Bagfilters, Cartridge filters, Hepa filters

Dust Concentration

- 0.01 mg/m³ to 10,000 mg/m³
(product specific)

Approval Range

- 0 – 30 mg/m³ (MCERTS/TUV)

Unique Features

- Unaffected by contamination of probe
- Optimised to tolerate changes of velocities >8 m/s (unlike Triboelectric systems)
- Zero and Span Checks
- Patented Probe Contamination check

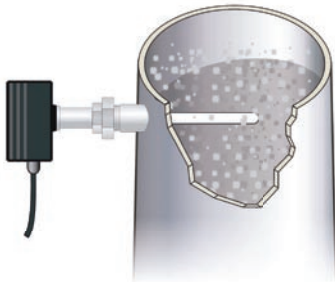

Hazardous Zones

For applications in Hazardous Areas, PCME provide a range of ATEX approved particulate monitoring systems, both Dust (Category 1/2 & 3) and Gas Zones (Category 0/1 & 2) accredited instruments are available. The ATEX product directive (94/9/EC) covers all equipment and protective systems for hazardous areas. Products are required to be categorised by the level of protection that they offer against the risk of them becoming a potential source of ignition in an explosive atmosphere.



PCME is a worldwide organisation dedicated to the innovation, design, development, manufacture and supply of continuous particulate emission monitors for industrial processes. With instruments monitoring over 10,000 emission sources in over 40 countries, PCME provide a comprehensive range of products (using a choice of technologies) for bagfilter performance optimisation and regulatory emission measurement from main stack emission point.

PCME recognizes that service support is a critical issue for industrial operators who may depend on the results from instruments as part of regulatory permits or to provide critical process details. PCME offers a complete range of technical services which include taking 'turnkey' responsibility for installing and commissioning monitoring systems. Robust scheduled maintenance and calibration contracts are available in support of installed systems, providing on-site and factory service training and of course providing responsive emergency breakdown service.

www.pcme.co.uk

Contact Your National or Area Sales & Service Office

DASTECS

Representantes / Distribuidores Exclusivos

Buenos Aires, Argentina

Tel.: (54-11) 5352-2500

E-mail: info@dastecsr.com.ar

Web: www.dastecsr.com.ar



PCME Ltd

Clearview Building 60 Edison Road

St. Ives Cambs UK PE27 3GH

Tel: Int +44 (0)1480 468200

Fax: Int +44 (0)1480 463400

E-mail: sales@pcme.co.uk