

Installation, Operation & Maintenance Manual

Sentry Single Line Single Line Conditioning Module

S-SW-IOM-00274-31 8-16



Table of Contents

Safety Information	3
General Safety Precautions	4
General Description	5
Specification	8
Principle of Operation	11
Installation.....	12
Operation.....	14
Troubleshooting	16
Maintenance.....	16
Parts List.....	18
Standard Warranty	20
Customer Support.....	21



Do not install, maintain, or operate this equipment without reading, understanding, and following the appropriate Sentry Equipment Corp instructions. Otherwise, injury, damage, or both may result.

Copyright

© 2016 by Sentry Equipment Corp. All rights reserved. All product and company names are property of their respective owners. This document contains proprietary information. No part of this document may be photocopied or reproduced without the prior written consent of Sentry Equipment Corp.

Limit of Liability

Sentry Equipment Corp, its employees, agents, and the authors and contributors to this document specifically disclaim all liabilities and warranties, express or implied (including warranties of merchantability and fitness for a particular purpose), for the accuracy, currency, completeness, and/or reliability of the information contained herein and/or for the fitness for any particular use and/or for the performance of any material and/or equipment selected in whole or part with the user of/or in reliance upon information contained herein. Selection of materials and/or equipment is at the sole risk of the user of this publication.

Note

The information contained in this document is subject to change without notice.

Safety Information

Please read the entire manual before attempting to unpack, set up, or operate this product. Pay careful attention to all Warnings, Cautions, and Notes. Failure to do so could result in serious personal injury and/or equipment damage.

Use of Hazard Information

If multiple hazards exist, the signal word corresponding to the greatest hazard shall be used.

Definitions

DANGER

DANGER indicates a hazardous situation which, if not avoided, will result in death or serious injury.

WARNING

WARNING indicates a hazardous situation which, if not avoided, could result in death or serious injury.

CAUTION

CAUTION, used with the safety alert symbol, indicates a hazardous situation which, if not avoided, could result in minor or moderate injury.

NOTICE

NOTICE is used to address practices not related to personal injury.

NOTE

Information that requires special emphasis.

TIP

Alternate techniques or clarifying information.

SHALL: This word is understood to be mandatory.

SHOULD: This word is understood to be advisory.

General Safety Precautions

Product Selection, Installation, and Use

WARNING

Improper selection, installation, or use can cause personal injury or property damage. It is solely the responsibility of users, through their own analysis and testing, to select products suitable for their specific application requirements, ensure they are properly maintained, and limit their use to their intended purpose.

Follow proper local, state, and federal regulations for proper installation and operational requirements.

Always use caution and common sense when working with any chemical. Read the product label and Material Safety Data Sheets (MSDS) carefully and follow the instructions exactly.

Potential Equipment Hazards

WARNING

Hot surfaces! This equipment may have very hot surfaces. If an operator contacts a hot surface, injury may occur. Use protective clothing to prevent injury. If other equipment comes in contact with a hot surface, damage to the equipment may occur. Ensure the area around this equipment is kept clear to prevent this damage from occurring.

High pressures! This equipment may contain fluids at very high pressures. Prior to installing, removing, or maintaining this equipment, ensure that the equipment is isolated from all connecting piping, the equipment is depressurized, the contents have been drained, and the equipment is cool.

General Description

Sentry® Single Line conditioning modules are pre-piped assemblies that include all the elements necessary to provide proper conditioning of steam and water for manual grab sampling and/or analysis.

There are four basic versions of the Sentry Single Line Sample System:

Model	Description	Rating (sample only)
SL100L	Low pressure, grab sample only	500 psig at 450°F (34.5 bar at 232°C)
SL100H*	High pressure, grab sample only	3030 psig at 1000°F (209 bar at 538°C)
SL200L	Low pressure, grab sample and analysis	500 psig at 450°F (34.5 bar at 232°C)
SL200H*	High pressure, grab sample and analysis	3030 psig at 1000°F (209 bar at 538°C)

*5000 psig at 1000°F (345 bar at 538°C) with optional high pressure inlet valve.

The cooling water circuit rating is 150 psig at 200°F (10.3 bar at 93°C)

Each style has a base configuration plus a variety of optional components.

Reference Figure 1 for a schematic of each type. Those items marked with an asterisk are optional.

Figure 2 depicts a SL200H with typical options. Note that dimensions may vary depending on options selected.

Standard models of Sentry sample panels are 12" (304.8 mm) wide x 36" high (914.4 mm).

Figure 1.

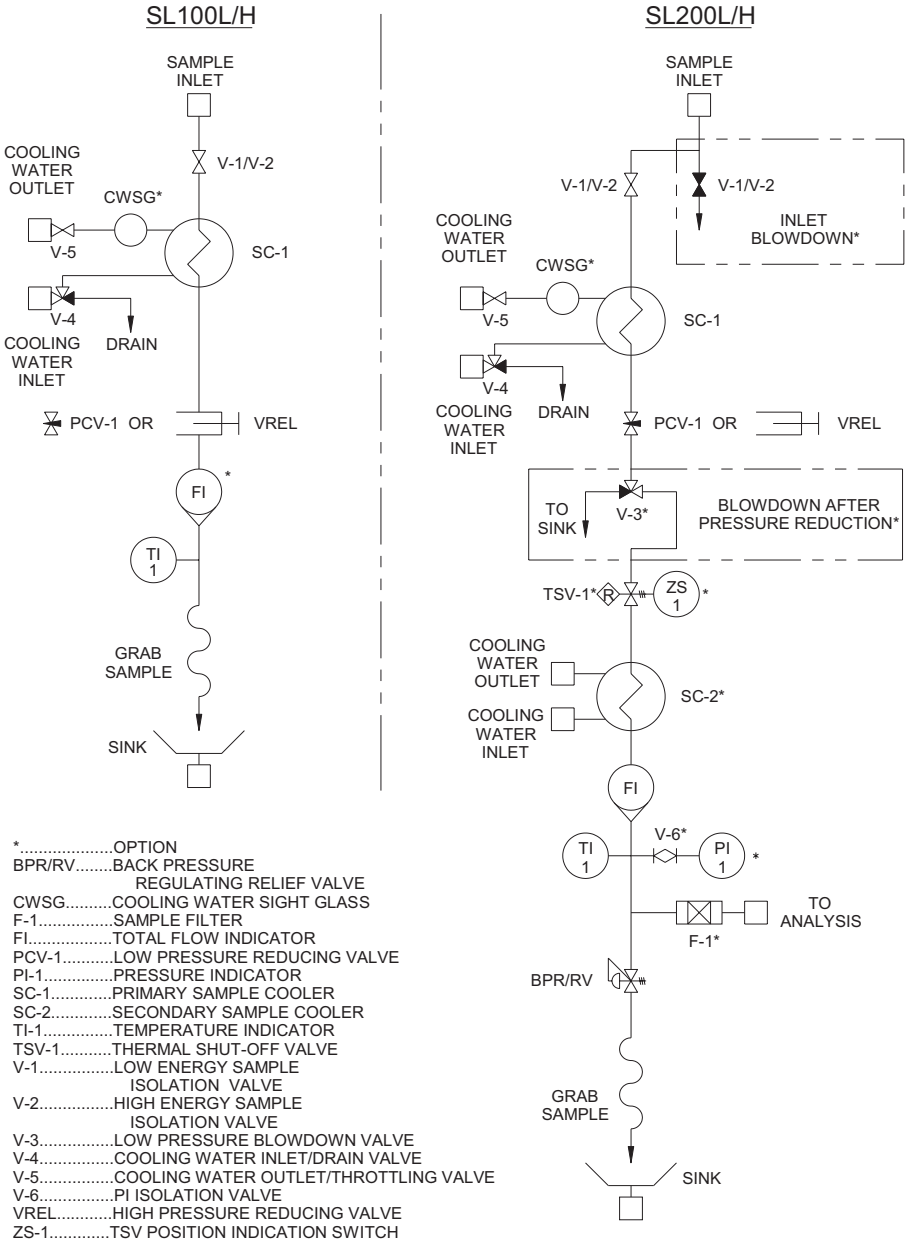
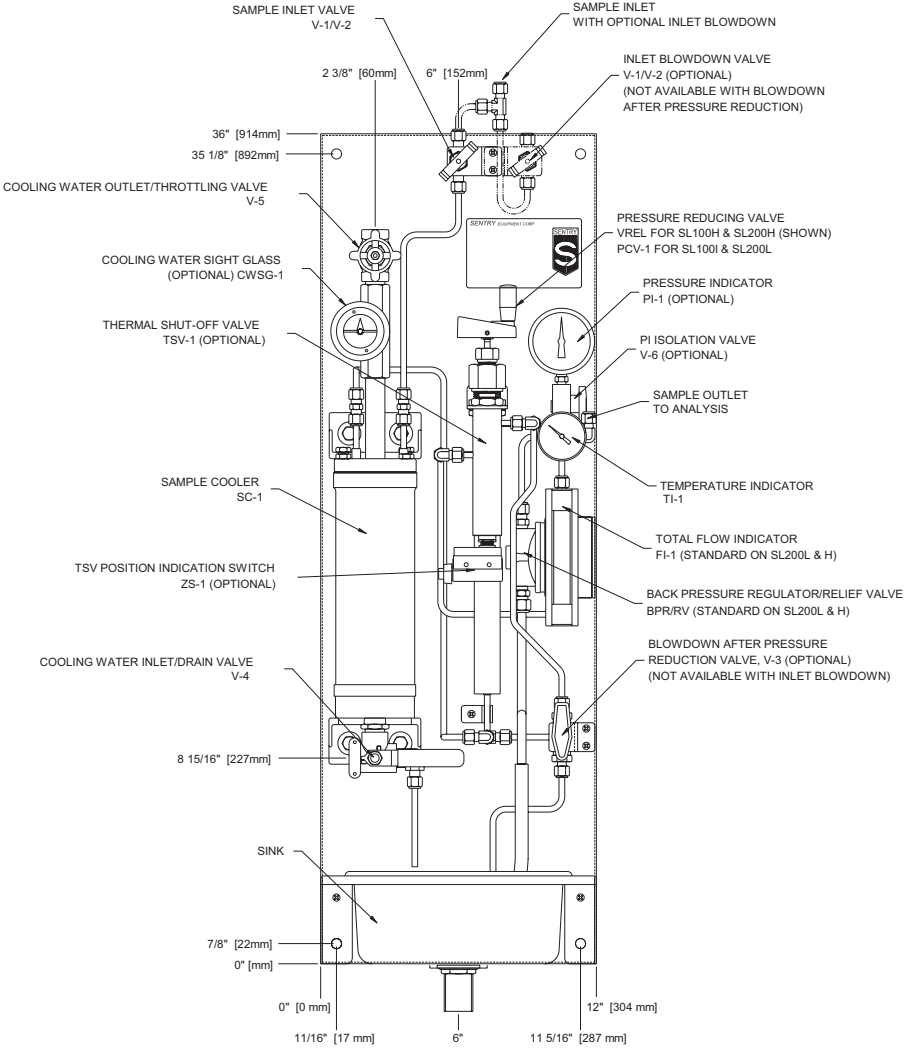

Figure 2. SL200H with Typical Options



Specification

Models SL100L & SL100H (Grab Sample Only)

The base configuration includes a back panel with the sample cooler, cooling water inlet and outlet valves, sample isolation valve, and flow control valve.

Primary Sample Cooler (SC-1)

The standard cooler is a Sentry TLR-4225. Other models are available upon request.

Sample Isolation/Blowdown Valve for Low Energy (V-1)

Samples where the temperature is less than 450°F (232°C) and the pressure is less than 500 psig (34.5 bar) are considered low energy and a needle valve with 1/4" compression fittings is used for these samples. The incoming sample line is connected directly to this valve or a customer supplied reducer/adaptor. The sample isolation valve is not used to reduce sample pressure or control the sample flow rate.

Sample Isolation/Blowdown Valve for High Energy (V-2)

Samples where temperature is greater than 450°F (232°C) or pressure is greater than 500 psig (34.5 bar) are considered high energy and a severe service needle valve with 1/4" compression fittings is used for these samples. The incoming sample line is connected directly to this valve or a customer supplied reducer/adaptor. The sample isolation valve is not used to reduce sample pressure or control the sample flow rate. The standard inlet valves are rated for 3030 psig at 1000°F (209 bar at 538°C). However, optional inlet high pressure valve is available with ratings of 5000 psig at 1000°F (345 bar at 538°C).

Cooling Water Inlet/Drain Valve (V-4)

The 3-way inlet/drain valve protects the cooler shell side from accidental over pressurization by eliminating the possibility of isolating the cooler. When V-4 is positioned to isolate the cooler from the cooling water source, the cooler shell is drained into the sink. If the shell side is not vented, the water trapped in the shell can heat up and expand if the sample is still flowing. The expanding water in the shell could result in pressure exceeding the shell side rating. Alternately a 2-way inlet isolation valve may be provided along with a relief valve (RV-1). The lever on the relief valve can be lifted to drain the cooler.

Cooling Water Outlet/Throttling Valve (V-5)

This globe valve allows adjustment of the cooling water flow rate. Cooling water should always be throttled on the downstream side of the cooler, not the inlet side.

Pressure Reducing Valve for Low Energy Samples (PCV-1)

On low energy samples a needle valve is used for pressure reduction and sample flow control.

Pressure Reducing Valve for High Energy Samples (VREL Valve)

On high-energy samples, a Sentry VREL® control valve is used for pressure reduction and sample flow control. The VREL valve is a non-wearing rod-in-tube pressure-reducing valve. A unique advantage of this type device is the ease at which crud can be passed through the system (See “Operation” section for details.)

↻ NOTE

The VREL valve is a rod-in-tube device. The pressure of the incoming sample is reduced as the liquid is forced to travel through the long narrow gap between the tapered rod and the tube I.D. Because the pressure reduction is done over the entire length of the rod, localized stresses are held to a minimum. The result is a very long service life compared with devices in which the pressure drop occurs over a very short distance (e.g. fixed orifice, pressure regulator, etc.).

⚠ CAUTION

The VREL valve is not a shutoff valve. The minimum flow obtainable is about 150 cc/min.

If the VREL valve becomes plugged, the rods can be fully retracted to allow the crud to pass. This can be performed without interrupting the sample flow or disassembling the VREL valve.

Temperature Indicator (TI) 0-250°F/-20-120°C

The temperature indicator indicates the temperature of the sample after cooling and pressure reduction. On models SL200L & SL200H, this is also the temperature of the sample going to the analyzer(s). The temperature indicator is not included with some Single Lines.

Sink Assembly

A stainless steel sink assembly with a drain is mounted on the panel under the grab sample. The sink drain is 1" NPS for individual Single Lines, 1-1/2" for wall and floor rack Single Line assemblies. The sink assembly is not included with some Single Lines.

Models SL200L & SL200H (Grab Sample & Inline Analysis)

Models SL200L & SL200H include the SL100 base components, along with the following components:

Fixed Backpressure Regulating/Relief Valve (BPR/RV)

Sample pressure to the analyzers is maintained by a fixed backpressure-regulating valve, which also acts as a sample line relief valve. The sample discharged from the BPR/RV is the grab sample. As long as sample is flowing from the BPR/RV, it holds a constant upstream pressure of 20 psi (1.4 bar) (standard, other pressures available) regardless of moderate fluctuations in process system pressure. Other fixed pressure set points are available.

Total Flow Indicator (FI) 0-1600 cc/min

The flow indicator is used to read the total flow through the system. The sample-throttling valve (PCV-1 or VREL) is used to adjust the flow rate of the sample.

When an in-line analyzer is used, it is important to have constant sample flow past the sensor because flow variations affect analyzer results. A valved rotameter (not included) is normally installed between the Single Line Panel and the analyzers, and is used to adjust the flow going to the analyzer. Since the BPR/RV maintains a constant pressure, the flow through the analyzer remains constant.

↩ NOTE

Many utilities prefer to do the initial sample cooling close to the sample source rather than tube the hot sample to a central area. The reasons include: more reliable chemical results, reduced thermal cycling of the sample tubing, and personnel safety. Pressure reduction of the sample can be carried out at the remote panel or where the grab sample is being taken. The latter is usually preferable because of operator convenience.

Optional Components (SL100 or SL200)

Inlet Blowdown Valve (V-1/V-2)

An optional inlet blowdown valve can be supplied at the inlet to the Single Line Panel. This option provides a means to reduce the amount of particles and sediment that accumulates in the sample line. The particles and sediment are removed when the blowdown valve is opened, by increasing the sample line flowrate. The outlet of the high-pressure blowdown valve is typically routed to a blowdown header.

Blowdown After Pressure Reduction Valve (V-3)

An optional blowdown after pressure reduction valve can be supplied after the cooler and pressure reducing valve. This type of blowdown is similar to an inlet blowdown, except the blowdown function includes the cooler and pressure reducing valve. This provides an effective and safe method of purging the sample line and some of the components from contaminants, which reduces the potential of plugging analyzer tubing. However, the effectiveness of the blowdown is reduced because flow must be limited to prevent boiling the cooling water inside the cooler. The blowdown after pressure reduction valve typically discharges to the sink.

Optional Components (SL200 Only)

Pressure Gauge (PI) – SL200 Option Only

Provides sample pressure readout at the analyzer connection. Under normal operation this gauge reads approximately 20 psig (1.4 bar) (with standard BPR/RV).

Secondary Cooling (SC-2)

Many analyzers require a sample temperature of 25°C (77°F) for accurate analysis. This is accomplished by installing a secondary cooler after the pressure reducing valve. In most applications, the secondary cooler maintains the sample temperature within one degree of the cooling water inlet temperature. The cooling water supplied to the secondary cooler is referred to as chilled water. By maintaining the chilled water at $76 \pm 1^\circ\text{F}$ ($25^\circ\text{C} \pm \frac{1}{2}^\circ$), the sample remains at $77 \pm 1^\circ\text{F}$ ($25^\circ\text{C} \pm \frac{1}{2}^\circ$). Temperature control of the chilled water is best accomplished by using a Sentry Temperature Control Unit (TCU).

Thermal Shutoff Valve (TSV-1), Position Switch (ZS-1)

This option provides for automatic shutdown of the sample flow in the event the sample temperature goes beyond a preset limit. As an added precaution this option requires a manual restart after shutdown. An optional position indication switch is also available. If this option is included, there is a separate manual attached for the TSV.

Cooling Water Sight Glass (CWSG)

A sight flow indicator installed on the cooling water outlet piping of the primary cooler. This allows operating personnel to verify cooling water is flowing through the sample cooler.

Analyzer Panels

In addition to the SL200L/H single line sample panel, Sentry Equipment can provide instrument panels to monitor a wide variety of sample properties. Specific information on the operation and maintenance of these instruments is provided in the manufacturer's instrument manual.

NOTICE

The sample isolation valve should never be used to throttle sample flow. The isolation valve has a small area of contact between the seat and disc. If it is used to throttle flow, pressure is reduced across a very small area. The sudden drop in pressure over a small area will cause the sample to flash into a steam/water mixture. This can damage the valve disc or seat and result in water hammer in the sample cooler when the steam bubbles collapse.

Principle of Operation

Cooling Water Circuit

Primary and Secondary

Most panels have a primary sample cooler. Cooling water is connected to the shell side of the cooler. (See "Installation" section.)

The cooling water must be throttled on the downstream side of the cooler, not the inlet side. This approach ensures maximum cooling water pressure, which reduces the chance of boiling inside the cooler shell. Boiling inside the shell encourages scaling and causes tube vibration and eventual fatigue failure.

Panels can have secondary coolers. Secondary cooling water (generally 76°F [28°C]) is connected to the cooler. (See "Installation" section.)

Sample Circuit

The sample enters through the inlet isolation valve (V-1/ V-2). This valve is selected based on the pressure and temperature of your sample.

The sample then passes through the primary cooler (SC-1), and into the pressure-reducing valve (VREL or PCV-1).

SL200 models can be equipped with an optional secondary sample cooler. This cooler is located after pressure reduction and is capable of cooling samples to within 1°F (1/2°C) of the cooling water temperature. The sample then flows past a thermometer (TI-1).

The sample then flows to the sink on SL100s.

On SL200s, a portion of the sample flow is diverted to the analyzer connection (at the thermo-well), and the remainder flows through the BPR/RV and grab sample line to the sink. A valved rotameter (not included) should be used at this point to provide a means to adjust and monitor flow going to the analyzer. A constant pressure is maintained between the pressure reducing valve and the BPR/RV as long as sample is flowing from the grab sample line.

When an in-line analyzer is used, it is important to have a constant sample flow past the sensor. Because the pressure is constant at this point, the flow through the analyzer remains constant. The fixed BPR/RV also acts as a sample line relief valve.

A valved rotameter (not included) is normally used to adjust sample flow through the analyzer.

Installation

WARNING

To ensure the protection provided by this equipment is not impaired, this equipment must not be installed or used in any manner other than that which is specified in this manual. Refer to additional literature included with equipment for instructions using third party materials.

Prior to installing, removing or maintaining this equipment, ensure that the equipment is isolated from all connecting piping, the equipment is de-pressurized, the contents have been drained and the equipment is cool.

NOTICE

SL Wall Racks – If factory mounted cooling water manifold is provided, lift the rack using the header. Lift from both ends. DO NOT lift from the middle.

SL Floor Racks – Lift panel with lifting eyes provided.

Receiving and Mounting

1. Examine the unit for any shipping damage. If in doubt, take pictures of the shipping container and any suspect area of the equipment. Report damages to the shipper at once. This is the responsibility of the consignee.
2. For individual Single Lines, bolt the units to the wall using four 3/8" bolts. (Typical all size panels.) To simplify installation, mount unistrut to the wall and then mount the SL to the unistrut. See Figure 2 for connection locations for a standard panel.
3. For Single Line wall rack assemblies, use 1/2" bolts or anchors to mount the rack to the wall or structural members. Every mounting hole in each vertical support of the wall rack frame should have a bolt or anchor to ensure proper support of the rack.

4. For Single Line floor rack assemblies, use four 1/2" bolts or anchors to secure the assembly to the floor, deck or pad.

Connections

Step 1: Connect cooling water inlet and outlet connections on primary and secondary coolers.

Primary Cooler (TLR-4225/FLR-6225)		Secondary Cooler (TLR-4225)		Secondary Cooler (FLR-6225)	
Inlet (bottom)	1/2" FNPT	Inlet (top)	3/4" FNPT	Inlet (top)	3/4" FNPT
Outlet (top)	1/2" FNPT	Outlet (bottom)	1/2" FNPT	Outlet (bottom)	3/4" FNPT

CAUTION

To maintain operator safety and prevent system damage, follow these steps carefully before opening the sample inlet valve (V-1/V-2):

1. The VREL valve or PCV-1 must be placed in the fully closed position (CW).
2. Cooling water inlet and outlet valves must be fully open. Throttle cooling water outlet valve (V-5) after sample flow is established.

NOTICE

When starting up a sample line that includes a VREL valve, always be sure that the rods are fully inserted (turn handle clockwise to insert rods) before opening the sample isolation valve. When the rods are fully inserted, the yoke bottoms in the barrel. When the rods are fully retracted, the yoke is stopped by the seal. **Do not try to turn the handle with excessive force at these positions!! The threads will be damaged.** After opening the isolation valve, adjust the VREL valve to achieve the desired flow rate.

If a wall mount or floor mount rack is purchased, and the unit has common headers, the customer must connect to the cooling water headers.

Step 2: Connect the sample lines.

S/L Panels w/ TLR-4225 Coolers	1/4" compression fitting
S/L Panels w/ FLR-6225 Coolers	3/8" compression fitting

Step 3: Connect sink drain line.

Sink Drain Size	1" NPS for individual sinks, 1-1/2" for wall and floor racks
------------------------	--

Operation

⚠ CAUTION

Cavitation can cause damage and failure of the equipment. Cavitation results whenever localized boiling occurs on the surface of a coil. Vapor bubbles form on the coil surface and are swept into the main stream of the fluid where they immediately condense and collapse. The collapsing bubbles generate severe shock waves (i.e. vibrations) which can fatigue and ultimately fracture the tube(s).

Vibration is the typical cause of sample cooler failure. Vibration is caused by two (2) conditions:

1. **Cavitation** results whenever localized boiling occurs on the outside surface of the hot heat transfer coil. Steam bubbles form on the shell side of the hot coil surface and are swept into the main stream of the cooling water where they immediately condense and collapse. The collapsing bubbles generate severe shock waves (i.e. vibrations) which can fatigue and ultimately fracture the heat transfer coil.

Cavitation is caused by: (a) the cooling water **flow rate is too low**, such that the water is overheated to its boiling point, and/or (b) the cooling water **operating pressure is too low**, such that the cooling water can **boil** at a low temperature.

Cavitation can be prevented if: (a) the cooling water and sample flows are kept within the design conditions specified in Sentry literature, and (b) the cooling water pressure is kept as high as possible—50 psig (3 barg) minimum recommended. To avoid reducing the cooling water pressure in the shellside, throttle only at the **cooling water outlet, never at the inlet**. The cooling water outlet temperature should not be allowed to exceed 140°F (60°C).

2. **Excessive cooling water flow** can cause vibration of the heat transfer coil due to the effect of vortex shedding. This can lead to coil failure and can be prevented by throttling the cooling water flow to design conditions.

⚠ CAUTION

If you hear vibration or rattling noises from the cooler, take corrective action to:

- Eliminate vibration from cavitation by adjusting cooler so that:
 - a. Cooling water inlet valve is fully open.
 - b. Cooling water flow is per design condition.
 - c. Cooling water shellside pressure is as high as possible.
 - d. Sample flow is reduced if necessary.
- Eliminate vibration from excessive velocity by throttling cooling water flow. Always throttle at the cooling water outlet.

Start Up

All Panels

1. Ensure the pressure-reducing valve (VREL valve or PCV-1) is fully closed (fully clockwise).
2. Initiate cooling water flow through the sample cooler by fully opening the inlet valve (V-4) and outlet valve (V-5). Verify that minimum required cooling water flow is occurring. If cooling water is untreated, its temperature rise should not exceed 30°F (17°C) so as to minimize scaling. Be sure that the outlet temperature does not exceed 140°F (60°C).
3. Open the sample isolation valve (V-1 or V-2) all the way.
4. Adjust the pressure reducing valve (VREL valve or PCV-1) to establish the desired flow. The sample discharges into the sink. Sample flow should be adequate to establish turbulent flow in the sample line between the sample source and the panel.
5. When necessary, throttle cooling water flow by partially closing the globe valve on the cooling water outlet line. Any valve on the cooling water inlet line must always be fully open.

SL200L and SL200H Panels Only

6. The total sample flow must be in excess of that required by the analyzers to assure grab sample flow. Typically, 1200 cc/min is recommended for 1/4" sample lines.
7. Adjust analyzer flow to the rate required by the manufacturer. Ensure that sample is still flowing into the sink from the BPR/RV. If not, open the pressure reducing valve (VREL valve or PCV-1) until a solid sample stream is established. This is the grab sample source. If it takes too long to get a sample, temporarily increase the flow rate to achieve adequate flow. When the sample is completed, return the flow rate to its normal level.

Troubleshooting

Symptom	Possible Problem(s)	Remedy
Elevated Sample Temperature	<ul style="list-style-type: none"> ▪ Loss of cooling water flow ▪ Increase in cooling water inlet temperature ▪ Scaled cooler ▪ Increased sample flow 	<ul style="list-style-type: none"> ▪ Check cooling water supply ▪ Reduce cooling water temperature or increase flow ▪ Chemically clean (see cooler maintenance) ▪ Adjust sample flow rate
Reduced Sample Flow	<ul style="list-style-type: none"> ▪ Plugged line ▪ BPR/RV failure 	<ul style="list-style-type: none"> ▪ Blowdown line and exercise flow control valve ▪ See Leaking BPR/RV
Leaking Valve Stems	Loose or worn packing	Tighten packing nut or replace packing
Leaking Cooler	Loose housing from thermal shock or worn gasket	Tighten bolts on head assembly or replace gasket if cut or worn
Leaking BPR/RV	Diaphragm failure	Replace diaphragm

Maintenance

WARNING

Hot Surfaces! This equipment may have hot surfaces. If an operator contacts a hot surface, injury can occur. Use personnel protective equipment to prevent injury. Ensure the area around this equipment is kept clear.

High Pressures! This equipment may contain fluids at very high pressures. Prior to installing, removing or maintaining this equipment, ensure that the equipment is isolated from all connecting piping, the equipment is de-pressurized, the contents have been drained and the equipment is cool.

Sample Cooler

Coolers require an occasional descaling of the shell side. This can be done chemically or mechanically. The frequency of this cleaning depends on the hardness level and the outlet temperature of the cooling water. When the difference between the cooling water inlet temperature and sample outlet temperature becomes excessive, it is time to descale the cooler. If the cooler is used in continuous steam service, demineralized cooling water may be required to avoid frequent descaling.

Disassembly & Reassembly

1. For heavily scaled coolers, disassembly is made easier by first dissolving the scale. Remove scale by circulating an inhibited sulfamic acid cleaning solution through the cooling waterside.
2. Replace used gaskets with new ones. After reassembly, pressurize shell and visually inspect for water leaks. Replace gaskets, which show visible leaks. Keep spare shell gaskets on hand for this need. Replacement gaskets are available; see "Parts List" for ordering information.
3. During reassembly tighten the bolts only enough so that shell side leaking does not occur. Over tightening can cause gasket failure.

VREL Valve/Needle Valve

In the event of a blockage, it can normally be cleared by fully opening the valve.

CAUTION

Do not exceed temperature and pressure limits during this process.

If the VREL valve seal develops a leak, the seal requires replacement. A VREL valve seal kit is available, see "Parts List" for ordering information.

Valve Packing

Occasionally during initial start up or restart of the sample panel, the inlet isolation valve packing leaks. If this occurs, remove the handle and tighten the packing nut and then replace the handle. If the packing continues to leak or other valves or O-rings require maintenance; see "Parts List" for ordering information.

Flow Meters

The interior surface of the flow meter can be cleaned by removing the protection shield and the glass tube. Remove the protection shield by carefully squeezing the sides together to release the retaining tabs. Remove the glass tube by firmly grasping the tube at the bottom and lifting up against the spring loaded upper tube adapter. Swing the bottom of the tube out to clear the lower tube adapter. Wipe the interior of the tube with a soft cloth. Replace the tube by reversing the above procedure. Be careful not to pinch the o-ring seals.

Backpressure Regulating/Relief Valve

The only serviceable part of the BPR/RV is the diaphragm. Detailed instructions are included with the replacement diaphragm. See "Parts List" for ordering information. No pressure adjustment is available.

Parts List

ID	Description	Sentry Part Number		
		Other	Parker	Swagelok
BPR/RV	Sentry Backpressure Regulator/Relief Valve:			
	20 psi (Standard)	7-00868A	—	—
	42 psi (optional)	7-00868B	—	—
	28 psi (optional)	7-00868C	—	—
	7 psi (optional)	7-00868D	—	—
	12 psi (optional)	7-00868E	—	—
	5 psi (optional)	7-00868F	—	—
	60 psi (optional)	7-00868K	—	—
	Replacement diaphragm for above	6-04084A	—	—
CWSG	Cooling Water Sight Gauge, Bronze (prior to 7/2006)	4-04557T	—	—
	Stainless (prior to 7/2006)	4-04557X	—	—
	Bronze (7/2006 and later)	4-05729B	—	—
	Stainless (7/2006 and later)	4-05729A	—	—
F	Filter, 60 micron	4-00484F	—	—
	Replacement element, 60 micron	4-00361H	—	—
	Filter, 140 micron	4-00484A	—	—
	Replacement element, 140 micron	4-00361A	—	—
FI	Flow Meter (1600 cc/min) Kynar ends w/o valve	6-02671B	—	—
	Flow Meter (1600 cc/min) Stainless Steel ends w/o valve	6-02671A	—	—
FICV	Flow Meter (0-580 cc/min) Kynar ends w/valve	6-02671D	—	—
	Flow Meter (0-580 cc/min) Stainless Steel ends w/valve	6-02671C	—	—
PCV-1	Low Pressure Sample Flow Control Valve	—	4-04791B	4-03578B
	Packing Kit for above	—	4-04002H	—
PI	Pressure Gauge (0-60 psi)	4-06054C	—	—
	Pressure Gauge (0-100 psi)	4-06054D	—	—
RV-1	Cooling water relief valve:			
	½" Bronze (mounted on cooler) 150 PSI	4-01141A	—	—
	½" Stainless (mounted on cooler) 150 PSI	4-00617D	—	—
	¾" Bronze (mounted on header) 150 PSI	4-01141B	—	—
	¾" Stainless (mounted on header) 150 PSI	4-03479J	—	—
SC-1	Sentry TLR-4225 Sample Cooler	7-03951A	—	—
	Gasket for above	2-03800F	—	—
	Sentry FLR-6225 Sample Cooler	7-03953A	—	—
	Gasket for above	2-03800E	—	—
TI	Thermometer (0-250°F)	4-00816G	—	—
TSV	Thermal Shut Off Valve:			
	(120°)	7-01137E	—	—
	(104°)	7-01137F	—	—
	(160°)	7-01137G	—	—
	(140°)	7-01137H	—	—
	(109°)	7-01137J	—	—
	(210°)	7-01137K	—	—
	(194°)	7-01137L	—	—
	(153°)	7-01137M	—	—
	(203°)	7-01137P	—	—

ID	Description	Sentry Part Number		
		Other	Parker	Swagelok
V-1	Sample Inlet Isolation/Blowdown Valves, Low Pres/ Temperature ¼" Compression	—	4-04002D	4-03599B
	Packing for above	—	4-05054D	4-00348F
	¾" Compression	—	4-04002V	4-00473A
	Packing for above	—	4-04002Z	4-00348L
V-2	Sample Inlet isolation/Blowdown Valves, High Pres/ Temperature ¼" Compression	—	4-04002U	4-01856Z
	Packing for Above	—	4-00350D	4-00348A
	¾" Compression	—	4-03858X	4-03247H
	Packing for Above	—	4-03614D	4-00348B
	¼" Compression – High Pressure option	—	—	4-01856H
	5000 psig (345 bar) rating	—	—	—
V-3	Low Pressure Blowdown Valve (3-way)	—	4-02361B	4-00465L
V-4	Cooling Water Inlet/Drain Valve (3-way), Bronze	4-01139G	—	—
	Stainless	4-00920D	—	—
	Cooling Water Inlet/Drain Valve (2-way), Bronze	4-01139B	—	—
	Stainless	4-00920J	—	—
V-5	Cooling Water Outlet/Throttling Valve, Bronze Globe	4-00787B	—	—
	Stainless Globe	4-04855B	—	—
	Bronze Angle (wall & floor racks)	4-04950B	—	—
V-6	PI Isolation Valve	—	4-05120A	4-03654D
VREL valve	VREL High Pressure Sample Flow Control Valve	7-00744A	—	—
	Seal Kit for above	6-02302C	—	—
ZS-1	TSV Position Indication Switch	4-03989D	—	—

Standard Warranty

Sentry Equipment Corp (“Seller”) warrants products manufactured by it and supplied hereunder (“Products”) to be free from defects in workmanship and, to the extent materials are selected by Seller, to be free from defects in materials, in each case for a period as defined in the table below:

Brand	Product Line	Warranty Period
Sentry®	<ul style="list-style-type: none">▪ Steam & Water Sampling Products and Systems▪ Solid & Powder Sampling Products and Systems▪ Gas Sampling Products and Systems▪ Liquid & Slurry Sampling Products and Systems▪ Pipeline Integrity Products	Eighteen months from date of shipment or twelve months from startup (whichever occurs first)
Waters Equipment	Steam & Water Sampling Products and Systems	Twelve months from date of shipment

To view the full warranty, go to www.sentry-equip.com/warranty.

Customer Support

With proven sampling expertise since 1924, Sentry products and services provide business operations the critical insights to optimize process control and product quality. We deliver true representative sampling and analysis techniques to customers around the globe, empowering them to accurately monitor and measure processes for improved production efficiency, output, and safety. Standing behind our commitments, we are determined to tackle any application, anywhere.

We know that running an efficient operation isn't easy. It requires thorough, careful analysis of controlled, real-time data achieved through reliable, accurate, and repeatable process monitoring and measuring. By effectively conditioning, sampling, and measuring gas, liquid, slurry, powder, solids, steam, or water within their production environments, our customers obtain the critical insights they need to control and optimize their processes.

Yet, controlling your processes also means reliable customer support throughout the life cycle of your equipment.

- Customer Service—General information, warranty claims, order management.
- Installation Service—For systems that require specialized expertise upon installation.
- Technical Support—Troubleshooting, training, and technical manuals.
- Field Service & Retrofits—When a problem needs immediate attention.
- Replacements Parts & Consumables—Order your replacement parts and consumables.
- Sentry ProShield Services—Select from four ProShield Guardian service plans providing different levels of support to protect your large system investments with regularly scheduled maintenance.

To learn more, go to www.sentry-equip.com/support.

This page is intentionally left blank.

This page is intentionally left blank.

Serving customers
in more than 50 countries
across six continents worldwide.



Sample. Monitor. Measure.

SENTRY

Any Application. Anywhere.

sentry-equip.com

966 Blue Ribbon Circle North, Oconomowoc, WI 53066 U.S.A. | +1-262-567-7256 | support@sentry-equip.com

DASTECS S.R.L.

Representantes / Distribuidores Exclusivos

 **Argentina**

Tel: (+54 11) 5352 2500

Email: info@dastecsrl.com.ar

Web: www.dastecsrl.com.ar

 **Uruguay** www.dastecsrl.com.uy

 **Paraguay** www.dastecsrl.com.py

 **Bolivia** www.tecdas.com.bo